



SPARKR&D

The splitboard binding company.

2014/2015
SPARK R&D CATALOG



Spark R&D, breaking trail since 2006.

Inventors of the first ever splitboard specific binding

– catalyst for the worldwide splitboarding revolution

THE CHRONICLES OF SPARK

Based out of Bozeman, Montana USA, Spark R&D is rider owned and operated dedicated to pushing innovation in splitboarding since 2006. It's been a banner season for us at Spark with the release of our new Tesla System bindings, and they are back again for next season with some flashy new colorways. Despite the busy year, we charged ahead with midnight design sessions and dawn patrol product testing missions to bring you some new and unique products for 2014/15: a splitboard-specific hardboot binding and crampon, a much sought-after heel locker, and an XS heel loop for the ladies. Back at HQ, we are moving forward with a doubled factory space with new machines and team members to continue developing and manufacturing the best splitboard bindings and accessories in the world. It's shaping up to be another fun-filled year at Spark, thanks for riding with us!



Rider: Mark Rainery // Photo: Chris Miller

SPARK R&D TEAM RIDERS



Ryland Bell



Luca Pandolfi



Marcin Jaskolka



Mark Rainery



Tamo Campos



Chris Coulter



Aurelien Routens



Sean Busby



Skylar Holgate



Elliott Bernhagen



Claudia Avon



Byron Bagwell

SELECT AWARDS

Backcountry Magazine Editor's Choice (2010, 2012, 2013, 2014)

Snowboard Magazine Platinum Pick (2011, 2012)

Prospera Business Network Entrepreneur of the Year (2011)

Transworld Snowboarding Editor's Pick (2010)

SIA Snow Show Daily Snowpress Innovation Award (2010)

ISPO Brand New Award for International Innovation (2010)

SPLITBOARD BINDING ANATOMY

In 2006 we built the world's first ever splitboard specific binding. Rather than having a normal snowboard binding bolted to an adapter plate, we integrated the ability for the binding baseplate to slide directly onto Voile pucks. The result was a stiffer, lower, lighter, and more responsive set-up in both tour and ride mode. We continued to tweak and develop these pin mount bindings and they ultimately evolved into our popular Blaze and Burner binding models.

Springboarding off of the pin mount model and interim prototype concepts, we decided it was time to take splitboard binding technology and performance to the next level. Our revolutionary Tesla System released in 2013/14 is the culmination of our years on the skin track, riding backcountry and our devotion to detail back at the drawing board. The integration of touring brackets, crampons and climbing wires into a fully self-contained pinless splitboard binding system gives riders a no hassle backcountry system with no unnecessary moving parts – just clean, simple design, all working together.

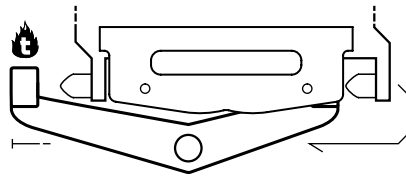
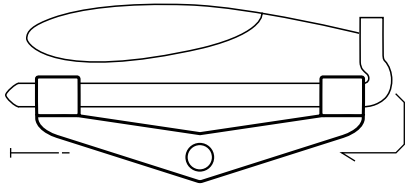

PIN MOUNT TOUR MODE

Used with our Blaze and Burner models, the pin is attached by a cable to the binding and is pushed all the way through the touring bracket, held into place by tucking the arm of the pin under the toe strap.

Patented with additional patents pending.

TESLA TOUR MODE

Used with our Magneto and AfterBurner models, the binding slides sideways into the offset touring bracket and is locked into place with our patent pending snap ramp. No pins, no cables, no fiddle factor.

US and International patents pending.

SIZING	US MEN'S	US WMN'S	EUR	MONDO
SMALL	<8	<9	<40	<25
MEDIUM	8-10.5	9-11.5	40-43	25-27.5
LARGE	11+	12+	43.5+	28+

Key Features of all Spark R&D Splitboard Bindings:

- CNC machined from billet aluminum for maximum strength.
- Custom splitboard specific highback has wide range of forward lean: from -5° for striding on the flats (an industry first!) to +25° for carving ice. Lateral slots in highback accommodate Strappy Straps for additional support and comfort on firm skin tracks.
- Low-profile plastics and buckles keep out of the way while skinning. Hardware manufactured with Burton's time-tested, bomber secret recipe of materials, and made to our specs.
- 3D ankle and toe straps are pre-curved for comfort fit using Burton fabrics – the industry leader in quality and durability.

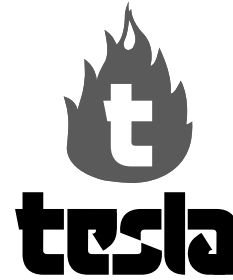

“10 Out of 10. The Most Innovative Change in Splitboarding Since the First Spark Binding.”

*~Editor of Backcountry Magazine
Backcountry Magazine Gear Guide (2014)*



Snap Ramps: No more pins. No more cables. Just lock down the toe ramp for both touring and riding.



Fatty Climbing Wires and Heel Rests: Dual height, full width, and built right into the baseplate. Easily operated with the basket of your pole.



Side-Lock Touring Brackets: Clog-free to make switchovers efficient and painless. Integrated crampon mounting claws.



Voile Puck Compatibility: Fully compatible with Voile pucks. The most functional way to attach your board in ride mode.



Sabertooth Crampons: Super easy to slide in and slide out on the fly. Keeps full teeth in the snow with either climbing wire height.

MAGNETO

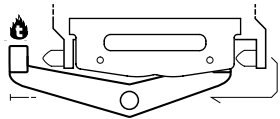

Black

Green

Navy



MAGNETO

The Magneto is a lightweight, nimble, pow slashing machine. Built with the Tesla System, this binding is ideal for long tours, epic overnights, and slicing and dicing through the trees. Baseplates feature maximum cutouts to shave weight, yet maintain strength and performance, and allow puck adjustment with bindings in place. The highback is soft torsionally for mobility while stiff fore-aft for heelside turn support. Ankle straps are supportive but flexible for quick turning.

Colors: Black, Green, Navy
Weight: 3.29lb/pr (1492g) - Medium

AFTERBURNER

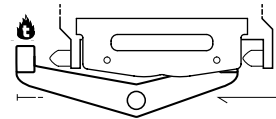

Oxblood

Brown

Black



AFTERBURNER

The AfterBurner is stiff and powerful for big mountain charging. Built with the Tesla System, this binding keeps a solid baseplate for max rigidity our bigger riders can trust. The highback is super stiff both torsionally and fore-aft for the aggressive rider looking for response. Ankle straps are wide and supportive and toe cap straps keep the rider firmly in place at mach speed.

Colors: Oxblood, Brown, Black
Weight: 3.52lb/pr (1596g) - Medium



SPARK R&D PIN MOUNT BINDINGS

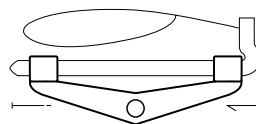

BLAZE

Back again for 14/15 is the time tested Blaze binding. Designed for the all-around adventurer looking for lightweight touring deep into the backcountry. Baseplates are cored out and paired with lighter straps for weight savings without compromised durability. Features a more flexible highback for a surfy ride down. *Stainless steel pin mount binding.*

Color: Black
Weight: 3.21lb/pr (1454g) - Medium

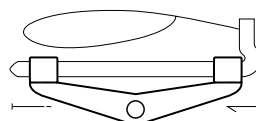

BURNER



The big mountain brother to the Blaze: stiffer components designed specifically for our bigger riders who prefer high-speed aggressive shredding. Features a solid baseplate, stiff highback, wide ankle strap and toe caps – your recipe for pointing it.

Stainless steel pin mount binding.

Color: Black
Weight: 3.5lb/pr (1588g) - Medium



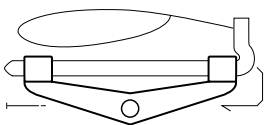
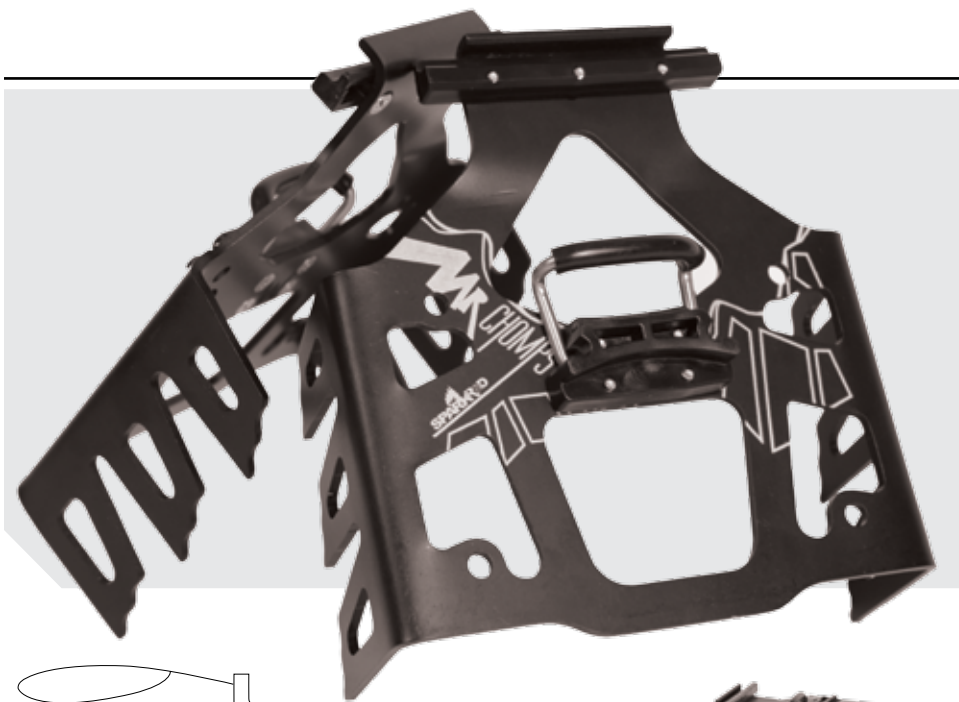

Black

MR. CHOMPS

Compatible with all Spark R&D pin mount bindings and the LT Pin System. Lean forward to easily position crampons under the touring pin and remove the same way. Riser mounted on crampon keeps same depth of teeth in the snow when using heel lifts. Can use in free or fixed mode depending on the terrain and snow surface.

Color: Black
Weight: 13oz/pr (362g) - Regular

SIZING	INSIDE WIDTH	
REGULAR	Boards 26cm waist or less. <i>(most boards)</i>	13.8cm
WIDE	Boards 26cm-28.5cm waist. <i>(select boards)</i>	14.8cm

Whether it's slick, steep, firm, or all of the above, crampons are your ticket to the top of surly skin tracks. Install on demand without having to unstrap or remove bindings from your board. Drop your splitboard into 4-low for times when secure ascents require more than just skins.



SABERTOOTH



Oxblood



Black

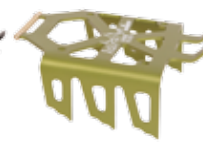

Green

Specifically designed to integrate with Tesla System bindings. Super easy installation and removal on the fly by sliding sideways into and out of the Tesla touring bracket claw mounts. Teeth are fully engaged when used with or without climbing wires for max security on any pitch.

Color: Black, Green, Oxblood
Weight: 11oz/pr (308g) - Regular





DYNO DH

DYNO DH

New for this season, the Dyno DH: Our first ever, hardboot specific splitboard binding! For years we have offered Dynafit toes and adapters for hardboot touring on the way up, the Dyno DH completes the package for the ride down.

- Extremely lightweight – only 381 grams per binding
- **Bomber** Indestructible Bomber Industry stainless steel bails and anodized aluminum toe clips
- Tesla System Snap Ramps for speedy, pinless transitions
- Voile puck compatible – canted pucks recommended
- Note: Binding is for ride mode only.
- Dynafit toe pieces, Voile climbing wires, and optional Dynafit Adapters are recommended for touring

Color: Black
Weight: 1.68lbs/pr (762g) - *Medium*

D REX CRAMPONS

Designed specifically for Dyna-Splitters, these crampons fit directly onto Dynafit Speed Radical toe pieces for the utmost confidence in dicey conditions. Install and remove on the fly by sliding sideways into and out of the Dynafit crampon claws. Riser mounted on crampon keeps same depth of teeth in the snow when using heel lifts.

Color: Black
Weight: 12.16oz/pr (344g) - *Regular*

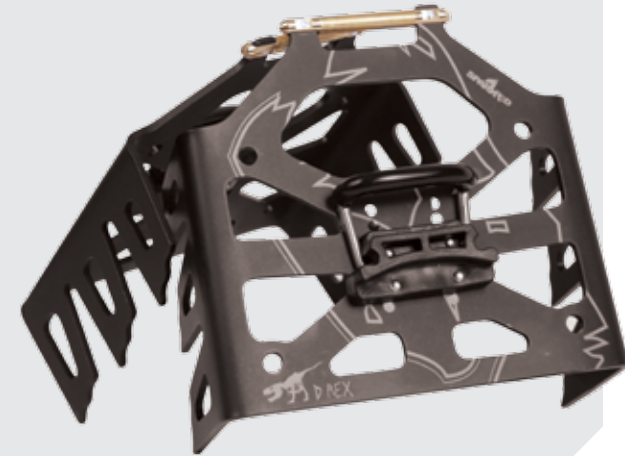

SPEED RADICAL TOE PIECES

Combining maximum functionality with minimum weight, the trademark Dynafit tech toe design securely locks the boot in place for confident touring. Light and fast, the Speed Radical toe pieces are your ticket to the top! *Combine with our Dynafit Adapter Plates for drill-free attachment.*

Color: As shown | Weight: 11.04oz/pr (313g)



DYNAFIT ADAPTERS

Our Dynafit adapters allow drill free use of Dynafit speed radical toe pieces for the part-time or full-time hardboot rider.

Colors: Black, Silver
Weight: .6.72oz/pr (192g)





Red



Black

TAILCLIPS

Tour with confidence, even backwards, knowing your skins are securely in place. The revolutionary Spark R&D Tailclips are a retro-fit addition to any skins – all you need is a hammer and scissors. Asymmetric clips designed specifically for splitboards are easy to remove and secure keeping skins tensioned parallel to length. US and International Patents pending.

- 10cm of tool-free length adjustment to fit your whole quiver
- Kit includes stretchers, clips, rivets, and webbing extenders for those of you with crazy long boards (or crazy short skins!)

Colors: Black, Red
Weight: 1.92oz/pr (54g)

STRAPPY STRAP

Less fatigue equals more fun in the backcountry. The Strappy Strap is designed to slot through Spark R&D highbacks and wrap around the top of your boot to provide additional support and edging power while touring.

Colors: Black, Red



VERTS

When skinning just isn't an option, post-holing shouldn't be either. Spark R&D has collaborated with Verts to offer a split friendly climbing alternative – the first ever splitboard specific snowshoe.

- Slide your Spark binding directly onto the adapter, no need for a separate snowshoe binding
- Designed specifically for ascending steep slopes
- Compact 18.75" x 8.5" (48cm x 22cm) footprint
- Toe forward design for fatigue-free front pointing
- High performance non-stick, super tough nylon
- Lightweight 2.46lb/pr (1117g)

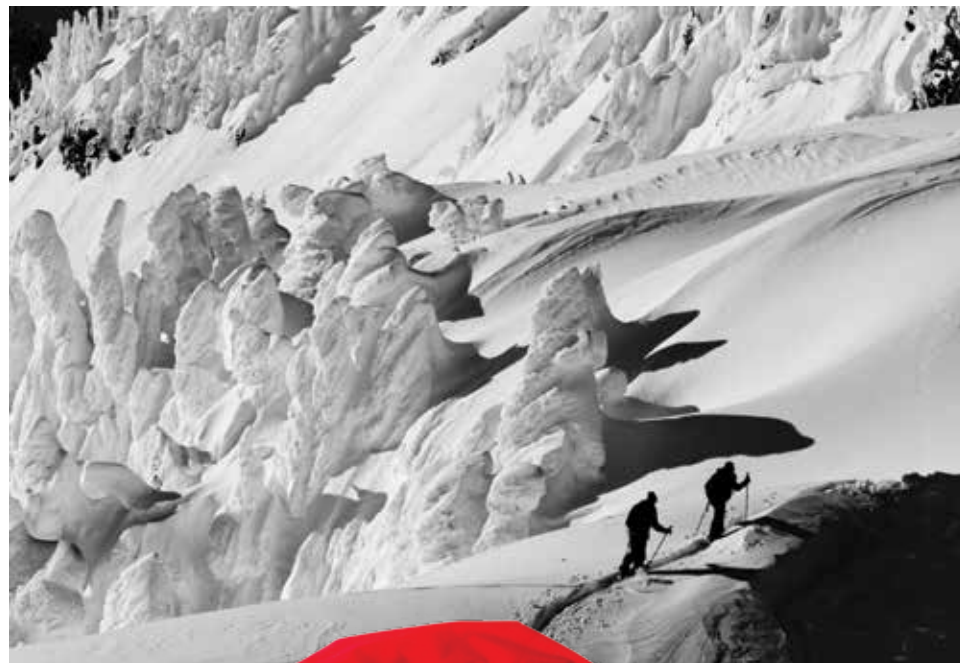

together with

SPLITBOARD SKINS

Our popular splitboard skins are back again! High traction skin material manufactured by G3 is the perfect combination of stick, slide, and grip. Equipped with our patent pending tailclips and killer GNARgyle print, these babies get you to the top with less effort and more style.

Color: GNARgyle
Weight: 1.63lb/pr (738g) - Medium

SML: 147-161cm / MED: 159-175cm / LRG: 172-186cm
*Please note new sizing recommendations



New this season, Spark R&D has teamed up with Black Diamond to offer the best touring poles for splitboarders.

Black Diamond

NEW Carbon Whippet



NEW Compactor

COMPACTOR

Sturdy, adjustable-length, aluminum Touring Series climbing poles ideal for splitboard travel. Z-Pole functionality deploys in seconds, and folds down to an ultra-compact and packable size for the ride down. Offers 20cm of adjustment for all conditions.

Color: Kelly Green

Sizes: Short: 41.3-55in (105-125cm)

Long: 45.25-53in (115-135cm)

Collapsed Length: 15in. (38cm)/15.75in. (40cm)

Weight: 1.38lb/pr (625g) - Short

CARBON WHIPPET

For steep, icy bootpacks and added self-arrest security on mega-steep, no-fall terrain. This is the most compact whippet you can find on the planet with 3-section packability; perfect for splitboarding. Stainless steel pick with canard wing built into a dual-density touring grip. Dual FlickLock Pro adjustability and security, rugged carbon fiber lowers. Compacts down to 70cm. Sold individually.

Color: BD Orange

Usable Length: 39-55in (100-140cm)

Collapsed Length: 27.6in (70cm)

Weight: 1.05lb/ea (475g)

NEW MOUNTING PLATES

Pucks for your solid board. The newly developed One Binding System brings Spark R&D into the quiver binding category. Perfect for trips where you are traveling with multiple boards, or days when you might see a mix of resort riding on your solid board, and side-country touring on your split. All you need is one pair of bindings – your Sparks.

Color: As Shown

Weight: 15.5oz/pr (438g)



Rider: Spark R&D Founder & Owner, Will Ritter, shredding cheddar in the Montana Backcountry

Photo: Patrick Lawrence



NEW

SPARK GEAR

Hats, T-Shirts and Hoodies. When worn with shoes, allows you ticket-free access to most public places!

Spark Hat: Mesh back keeps you cool on Spring tours.

Colors: Assorted



Split Kit Tee



Spark Mountain
Logo Hoody



MAGNETO AFTERBURNER



AfterBurner Kit

Magneto Kit

TESLA BASEPLATE KITS

For those splitters who already have a set of Spark pin mount bindings, but are now ready for the Tesla System. Switch the heel loop, ankle and toe straps onto Tesla baseplates and you are ready to rock. Comes with baseplate, Tesla bracket, heel rest, and hardware. Compatible with 12/13 pin binding models and beyond. Compatible with 11/12 Blaze and Burner bindings with the addition of the Heel Loop Kit which is sold separately.

Color: Black // Magneto: 1.55lb/pr (705g) / AfterBurner: 1.38lb/pr (784g)



2ND BOARD KIT – Set up multiple splitboards to be tour-ready with Tesla System bindings. Comes with Tesla brackets, Heel Rests, and screws. Pair it up with the Voile Puck Only kit and you're ready to ride.

Color: Black | Weight: 5.44oz/pr (152g)



HEEL LOOP KIT – For use with the Tesla Baseplate kit, these loops upgrade your 2011/12 Blaze & Burners into Tesla Bindings.

Color: Black | Weight: 6.56oz/pr (184g)

NEW HEEL LOCKER



You asked, we answered. New add-on for the Tesla System this season, Heel Lockers attach to the Tesla heel rest and are easily operated with the tip of a ski pole. Riders now have the ability to lock down the heel in tour mode to better adapt to diversified terrain types where quick descents, side-stepping, traversing, and skate-splitting become more effective means of backcountry travel. Better yet, these are forward releasable as an extra safety measure.

Color: Stainless | Weight: 1.28oz/pr (35g)

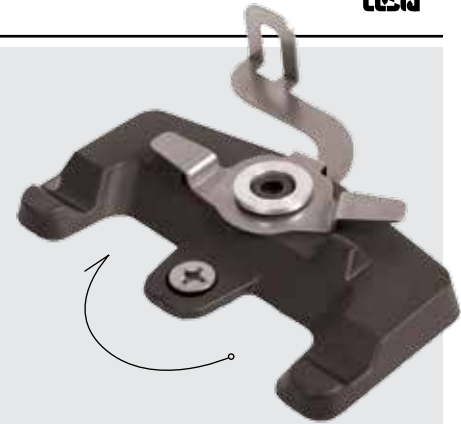

Rider: Patrick Lawrence Photo: John Parker

LT PIN SYSTEM

Our “LT” or “Lightweight Touring” pin system is an aluminum pin and bracket combination used to upgrade our Blaze and Burner pinmount bindings that come standard with stainless steel pins. Designed for splitboarders looking for better performance and durability, the LT Pin system is stiffer, lighter, and more slop free for near frictionless touring.

Color: Black
Weight: 3.84oz/pr (109g)

LT SPARE PINS – Aluminum spares for the cool kids with the LT Pin System. *Available for Blaze/Burner models.*

LT BRACKET KIT – For your second splitboard setup, LT Style. *Includes LT Brackets, LT Shorty Bars for Chomps compatibility, and screws.*

STAINLESS STEEL PINS – Spare pin kit for use with Voile touring brackets. *Available for Blaze/Burner models.*



BACKCOUNTRY KIT – Everything you need to keep a pow day from being cut short. *Includes spare plastics, screws, and buckle.*



VOILE HARDWARE – Now get your Voile hardware directly from Spark! When Paired with a factory splitboard and Spark R&D bindings, your ride is complete.

Choose from three hardware kit options:

- Voile Pucks Only (*pictured*): Just the pucks. Pair with our Tesla System bindings.
- Voile Universal Split Kit: The full kit. Use with our pin mount Blaze and Burner Bindings.
- Voile Canted Pucks: NEW for this season! Keep your knees happy. Compatible with all Spark R&D Bindings; recommended for our new Hardboot binding. **3° Cant**

DEALER SPARE PARTS KIT – A one-stop-shop to service your Spark R&D Binding & Hardware fleet.

NEW

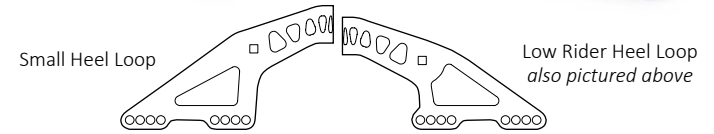

LOW RIDER HEEL LOOPS

NEW for this season, to accommodate requests from the not-so-tall splitboard community, we’ve made a size XS heel loop. The shorter height loops help position highbacks lower on the leg for a better calf fit. Mounting holes are shifted forward, allowing our small bindings to now fit down to a Women’s size US 5 (Mondo 22). Compatible with 12/13 and beyond Blaze/Burner bindings and all Tesla System bindings.

Colors: Black | Weight: 5.44oz/pr (155g)



Photo: Dan Milner

SPARK TOOL – Your best friend in the backcountry, this tool has everything you need to adjust your splitboard setup.





sales@sparkrandd.com
+1 406 580 7674

SPARK R&D
P.O. Box 3284
Bozeman, MT 59772, USA

 sparkrandd.com